

Zebra GK420d Label Printer Troubleshooting Guide

STATUS LIGHT ERRORS

No Light - Printer not receiving power

- Check to make sure Power Switch is in the On position
- Check power connections from wall to adapter to printer

Solid Green Light - Printer is idle

- Check Interface Connectors in the back of the printer

Double Flashing Green - Paused

- Press the Feed Button to continue printing

Flashing Amber - Stopped

- Turn the Power Switch off and then on

Flashing Red - Stopped

- Check label roll to make sure it has not run out of labels
- Check to make sure label roll is secure on Media Guides (black)/Media Hangers (green)
- Check to make sure top cover is closed

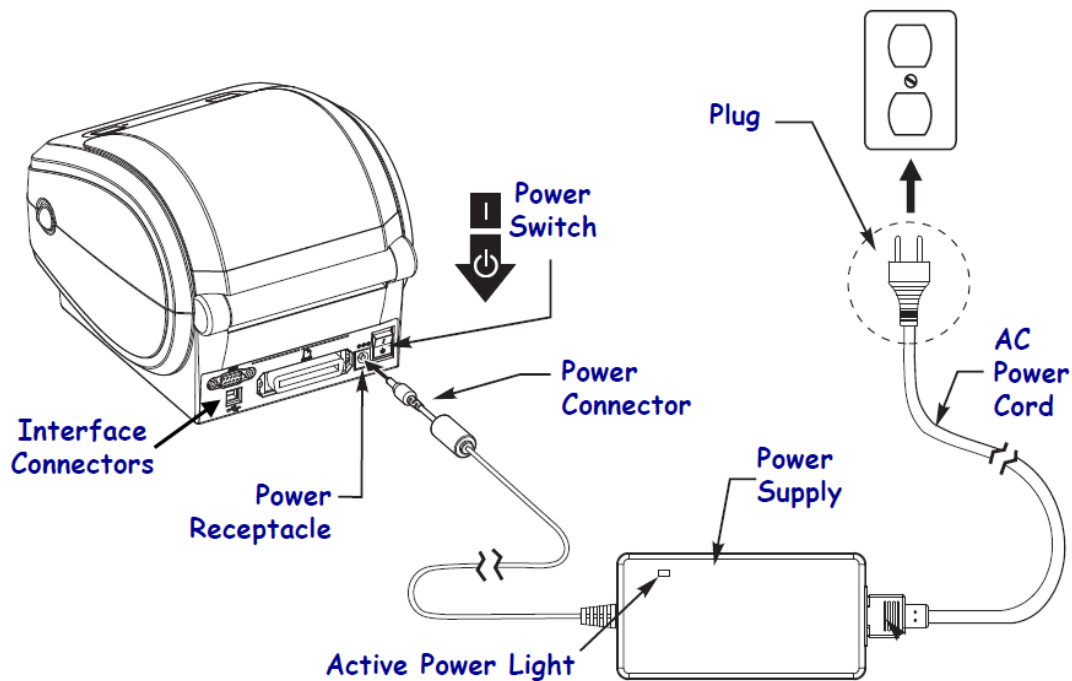
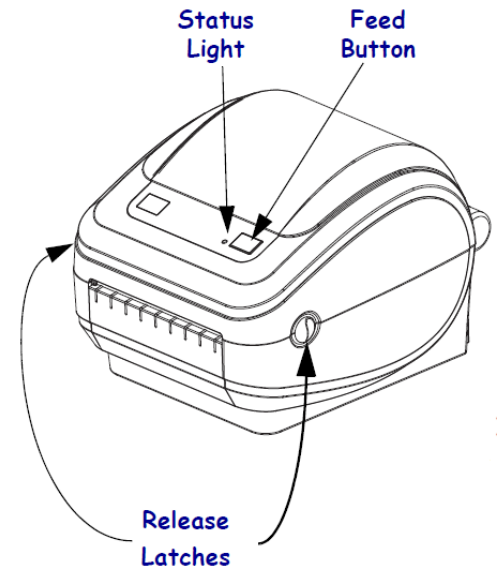

Label Printer Troubleshooting Guide p.2

PRINT QUALITY PROBLEMS

No print on the label

- Check to make sure the label roll is loaded correctly

The printed barcode and information does not look right

- Clean the printhead using an alcohol wipe

The label is misaligned

- Check to make sure the label roll is loaded correctly
- Contact Clients Services to have printer calibrated

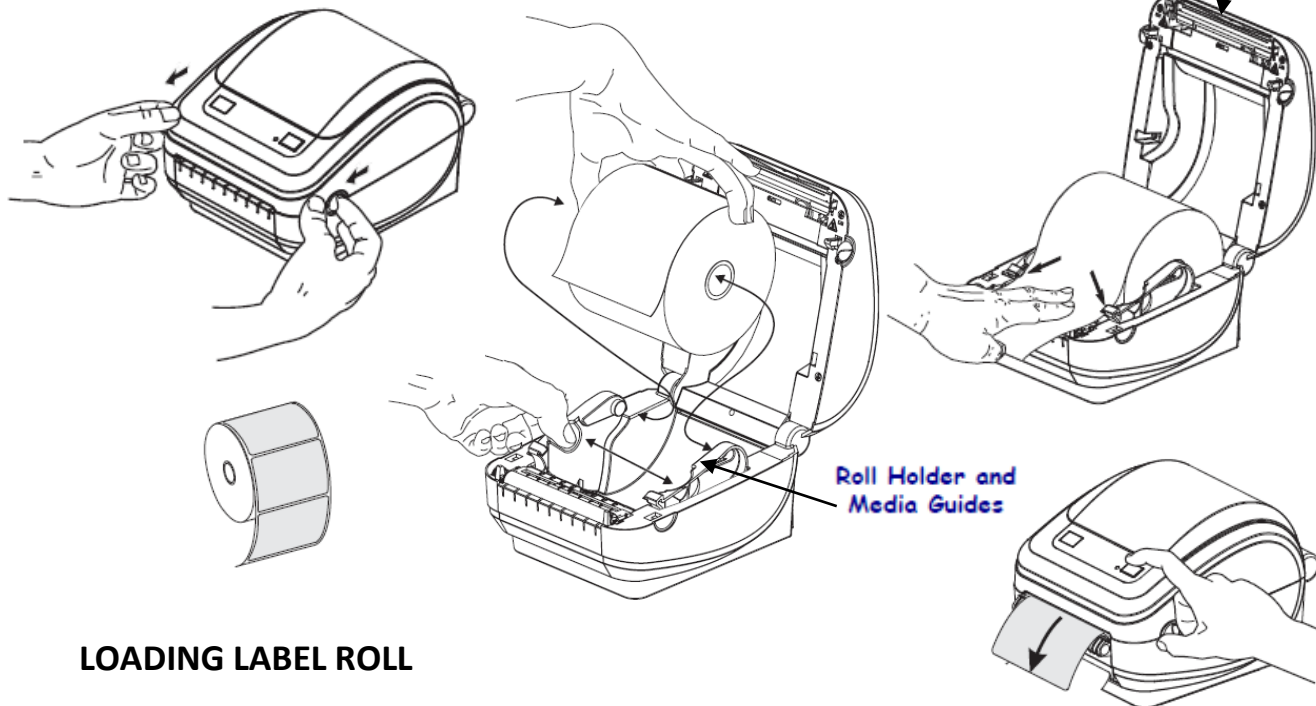

LOADING LABEL ROLL

1. Pull the release latches toward the front of the printer
2. Open the Media Guides and hold open the Media Hangers
3. Lower the roll between the hangers
4. Make sure to position the roll so that its printing surface will be up as it passes over the media guides
5. For some models, close the media guides by turning the guide adjuster knob to the front
6. The media guide edges should touch but should not restrict the edges of the roll
7. Close the top cover and press down until the latches snap into place
8. Press the Feed Button to verify that the labels come out properly

If you have any questions, please contact Client Services at 800.800.5655, Option 1.